

INCLINED BELT CONVEYOR

AMOS – AE

The AMOS belt conveyors are designed and engineered to fit into any new or existing grape reception layout. The structure is completely constructed in stainless steel AISI 304.



Standard Equipment:

- Electric motor installed on lower pulley
- Electrical control with ON/OFF and emergency switch
- Easy to clean and sanitize
- Food grade belt with V profiles every 10"
- Variable unloading height, adjustable with hydraulic jack, equipped with hand pump
- Frame on four pivot casters with brakes
- Choice between 3 standard hoppers

Options:

- Custom made loading hopper
- Open grape chute (4 different mounting options)
- Special grape chute for the use of flexible hoses
- Flexible hose (1 meter)
- Variable mechanical adjusted speed motor < 0.75 kW
- Variable electronic adjusted speed inverter < 1.1 kW

Model	Axis Belt Length	Belt Width	Unloading Height Min.	Unloading Height Max
AE30250F	8' 3"	1'	3' 8"	5' 11"
AE30350F	11' 6"	1'	4' 11"	8' 3"
AE30500F	16' 5"	1'	7'	11' 7"
AE50300F	9' 10"	1' 8"	4' 1"	7' 6"
AE50400F	13' 2"	1' 8"	5' 6"	9' 1"
AE50500F	16' 5"	1' 8"	6' 10"	11' 11"

VIBRATING SORTING TABLE

AMOS – AV

The AMOS vibrating sorting tables are designed and engineered to fit into any new or existing grape reception layout. The structure is completely constructed in stainless steel AISI 304, on height adjustable legs.

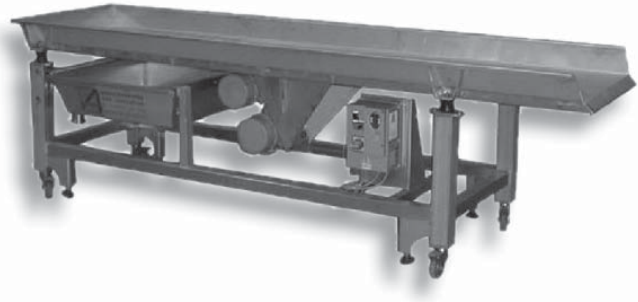

Standard Equipment:

- Body entirely made in stainless steel AISI 304
- Working width 27.6"
- Working height 33.5" ± 2"
- Variable speed control with electronic inverter
- Perforated surface on first part of the table
- Juice pan with 2" outlet
- Installed on legs with pivot casters complete with breaks
- Control panel with speed control and emergency switch

Options:

- Loading hopper
- Filter inlet for juice pan
- 2nd draining surface with juice pan (only for 18' table)
- Filter inlet for 2nd juice pan (only for 18' table)

Model	Length	Width	Total Width
AV70150V	5'	2' 4"	2' 9"
AV70300V	10'	2' 4"	2' 9"
AV70550V	18'	2' 4"	2' 9"