

AUTOMATIC FERMENTERS

Defranceschi

CE – PUMP-OVER SYSTEM

Automatic fermenters with pumping-over cap sparger, fermentation temperature controller and power-operated pomace discharger. Range between 2,900 and 26,400 gal.

Includes:

- Valves (sample, racking, discharge and cooling).
- Adjustable feet.
- Electrical control panel with temperature control and pump-over cycles.
- Cooling/heating jackets on side of tank.
- Low speed pump over pump with sparger (motorized on bigger models).
- Gear motor driven discharge blade for pomace removal.

MODEL	GAL	DIAMETER	HEIGHT
110 CE	2900	7' 5"	13' 9"
150 CE	4000	7' 5"	17' 1"
200 CE	5300	7' 5"	21' 2"

More sizes available on request.

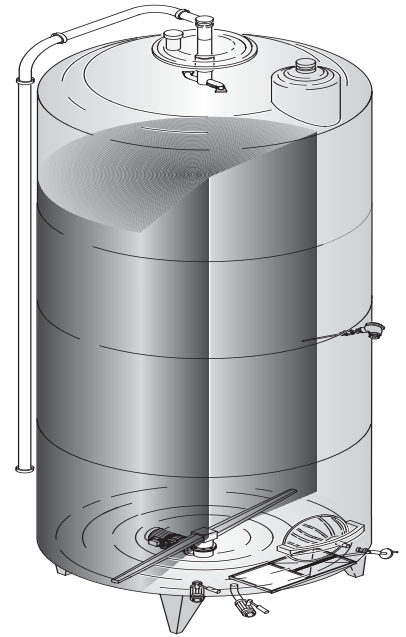

FERMENTAMATIC – PUMP-OVER SYSTEM

Automatic fermenters with central filter column for pump-over with filtered must. This feature allows more skin contact and assist CO2 extraction. Fermentation temperature control and power-operated pomace discharge system. Range between 2,900 and 26,400 gal.

Includes:

- Valves (sample, racking, discharge, cooling and pneumatic).
- Adjustable feet.
- Electrical control panel with temperature control, pump-over cycles.
- Cooling/ heating jackets on side of tank.
- Low speed pump over pump with motorized (bigger models) sparger.
- Central filter screen.
- Gear motor driven discharge blade for pomace removal.

MODEL	GAL	DIAMETER	HEIGHT
110 FE	2900	7' 5"	13' 9"
150 FE	4000	7' 5"	17' 1"
200 FE	5300	7' 5"	21' 2"

More sizes available on request.

