

AUTOMATIC FERMENTERS

Defranceschi

3000CP- PUNCH DOWN SYSTEM

Automatic fermenters with pneumatic cap plunging pistons, fermentation temperature control and optional power-operated pomace discharge system. Range between 900 and 13,200 gal.

Includes:

- Valves (sample, racking, discharge, cooling and pneumatic).
- Adjustable feet.
- Electrical control panel with temperature control and plunging cycles.
- Cooling jackets for heating or cooling the tank.
- Pump over tube and splash plate standard on 110Cp and bigger models.

Options:

- Gear motor driven discharge blade for pomace removal (models 90Cp and up).

MODEL	GAL	DIAMETER	HEIGHT
34 CP	900	5' 4"	11' 3"
50 CP	1300	5' 10"	13' 11"
75 CP	2000	6' 10"	13' 11"
90 CP	2380	7' 5"	14' 7"
110 CP	2900	7' 5"	16' 11"
130 CP	3400	7' 5"	18' 6"
150 CP	4000	7' 5"	20' 10"
200 CP	5300	7' 5"	24' 6"

More sizes available on request.

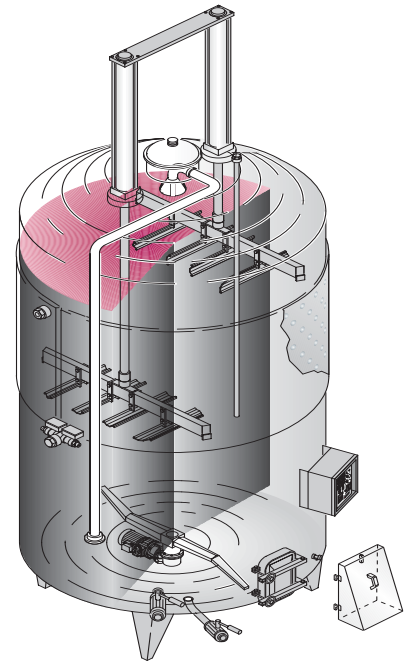

PUNTAROSSA - PUNCH DOWN SYSTEM

Automatic fermenters with pneumatic cap plunging pistons, automatic pump-over, possibility of removing the seeds during fermentation, fermentation temperature control and power-operated pomace discharge system. Range between 2,900 and 13,200 gal.

Includes:

- Valves (sample, racking, discharge, seed extraction, cooling and pneumatic).
- Adjustable feet.
- Electrical control panel with temperature control, pump over and plunging cycles.
- Cooling jackets on side of tank and heating jacket on bottom of the tank.
- Low speed pump-over pump with motorized (bigger models) sparger.
- Filter screen in bottom for pump over.
- Gear motor driven discharge blade for pomace and seed removal.

MODEL	GAL	DIAMETER	HEIGHT
110	2900	7' 5"	17' 7"
130	3400	7' 5"	19' 2"
150	4000	7' 5"	21' 6"
200	5300	7' 5"	25' 2"

More sizes available on request.

